



PORTFOLIO

DATA CENTER



C R E A T I N G A B E T T E R R E A L I T Y

ATI | Project

Table of contents

Profile pg. 5

Works

- ECMWF Data Center Buildings pg. 6
- Nyt OUH University Hospital pg. 10
- Bispebjerg Hospital pg. 16
- Tallinn Hospital pg. 20



PISA
MILAN
BELGRADE
ODENSE
COPENHAGEN
PARIS
GENEVA
TALLINN

▲ PROFILE

Creating a better reality

Architecture, landscape and technology conceived as a source of inspiration and enrichment of everyday life.

ATI Project is an international firm specialized in **integrated design** in the field of architecture and engineering, committed to the development of **sustainable buildings** with a reduced environmental impact.

The studio was established in 2011 by **Branko Zrnic** and **Luca Serri**, founders dedicated to research in bioclimatic architecture and renewable energy.

In just over a decade, the **team** has grown from **2 to 350 collaborators**.

The initial outline of the office is the same that still drives its growth today: a young, visionary, technological studio that

natively uses BIM to promote **multidisciplinary**, as well as **innovation** and **sustainability**.

The complexity and number of projects reflect the **internationality** of the studio, which today, in addition to its headquarters in **Pisa**, has offices in **Milan, Belgrade, Odense, Paris, Copenhagen, Geneva** and **Tallinn**.



14

YEARS OF CONSTANT GROWTH



25 Mln

TURNOVER IN EUROS



8

INTERNATIONAL OFFICES



1+ Million of m²

OF COMPLETED OR ONGOING PROJECTS



Main entrance

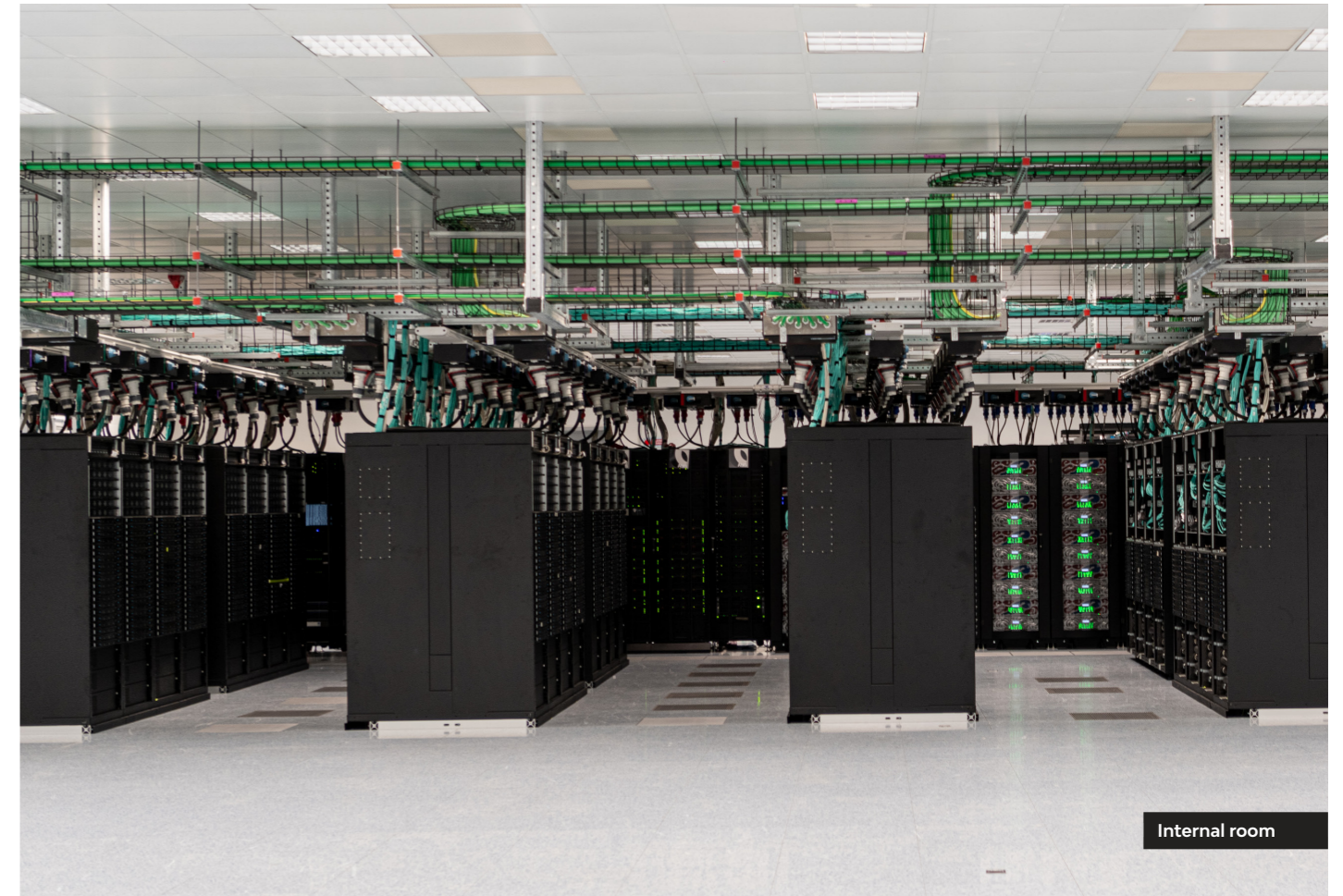

Internal room

Respect and innovation are the key words of this complex intervention, which converts part of a historic architecture into an avant-garde data centre, using BIM methodology.

DATA CENTER

ECMWF Data Center Buildings

A meteorological centre in Bologna's former tobacco factory

The new **ECMWF Data Center**, European center for medium-term weather forecasts, is characterized by the **high degree of complexity of the intervention**, on a global level.

The meteorological center covers an area of about **20.000 square meters** and is inserted within a part of the area of the **former Tabacchi Factory in Bologna**, designed and built by the architect **Pier Luigi Nervi** in the **1950s** and subjected to protection by the **Cultural and Landscape Heritage of Emilia-Romagna** for its high historical and engineering value.

The need therefore consisted in **re-functionalizing part of the existing complex** by creating a complex

infrastructure to establish the data center and – at the same time – interacting respectfully with the **pre-existing architectural context**.

Function and conservation find their synthesis through the advanced use of BIM, which accompanied the project management throughout the construction phase and for all disciplines, up to the development of the as built.

This methodology becomes the starting point for an **optimized management of the structure**, a need increasingly aimed at the **sustainability** of the complex and the **safeguarding** of an architecture created by an internationally renowned designer.

Location:
Bologna, Italy

Typology:
Renovation

Year:
2018 - 2022

Status:
Design & construction completed

Budget:
€ 42.8 mln (IT technologies not included)

Dimensions:
Approx. 17.000 sqm project surface,
9.000 sqm building surface

Client:
RTP Frimat - Site - Gianni Benvenuto

Activities:
Constructive BIM Design and Project Management, including Cloud point survey, shop drawings and As built

Credits:
Architectural Design and Coordination: GMP Architekten Von Gerkan, Marg and Partner
Plants Design: Studio T
Structural Design: Werner Sobek Stuttgart
Landscape: LAND Italia



Internal room



Internal room

Ground floor plan - Buildings B2 & B3

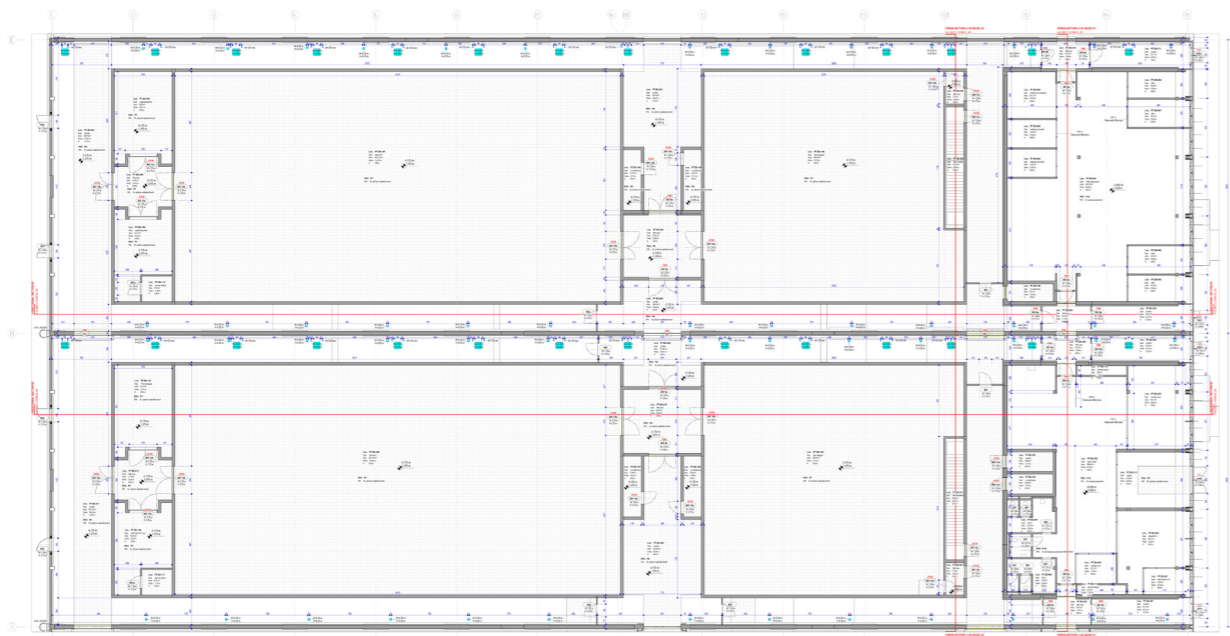

BUILDING DATA

- Power: 10 MW electric power
- Housing 80%+ of the national computing power and 20% of the European
- Main HPC (high performance computer) hosted: Atos, Leonardo, Lisa
- 5 DRUPS of 2 MW each, for a total of 10 MW



Model screenshots

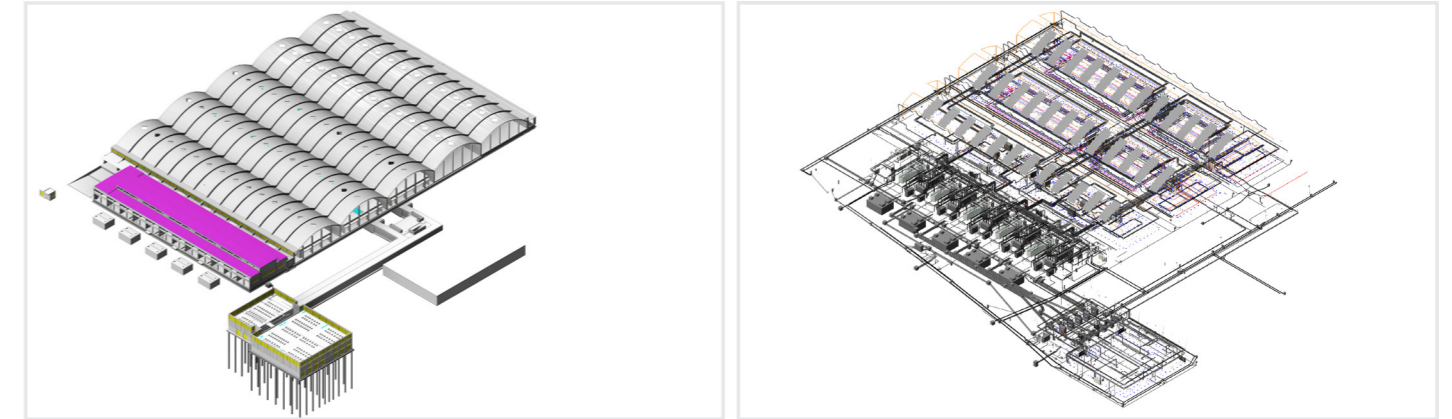

MEP details

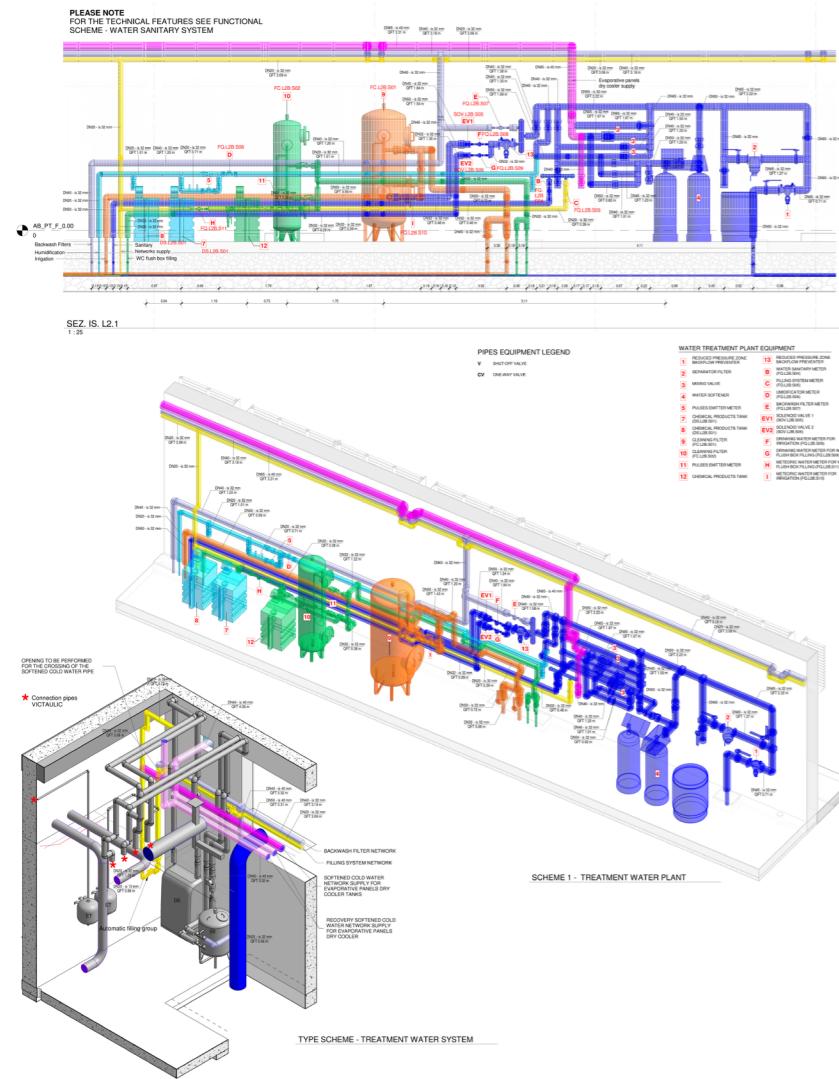

Photos

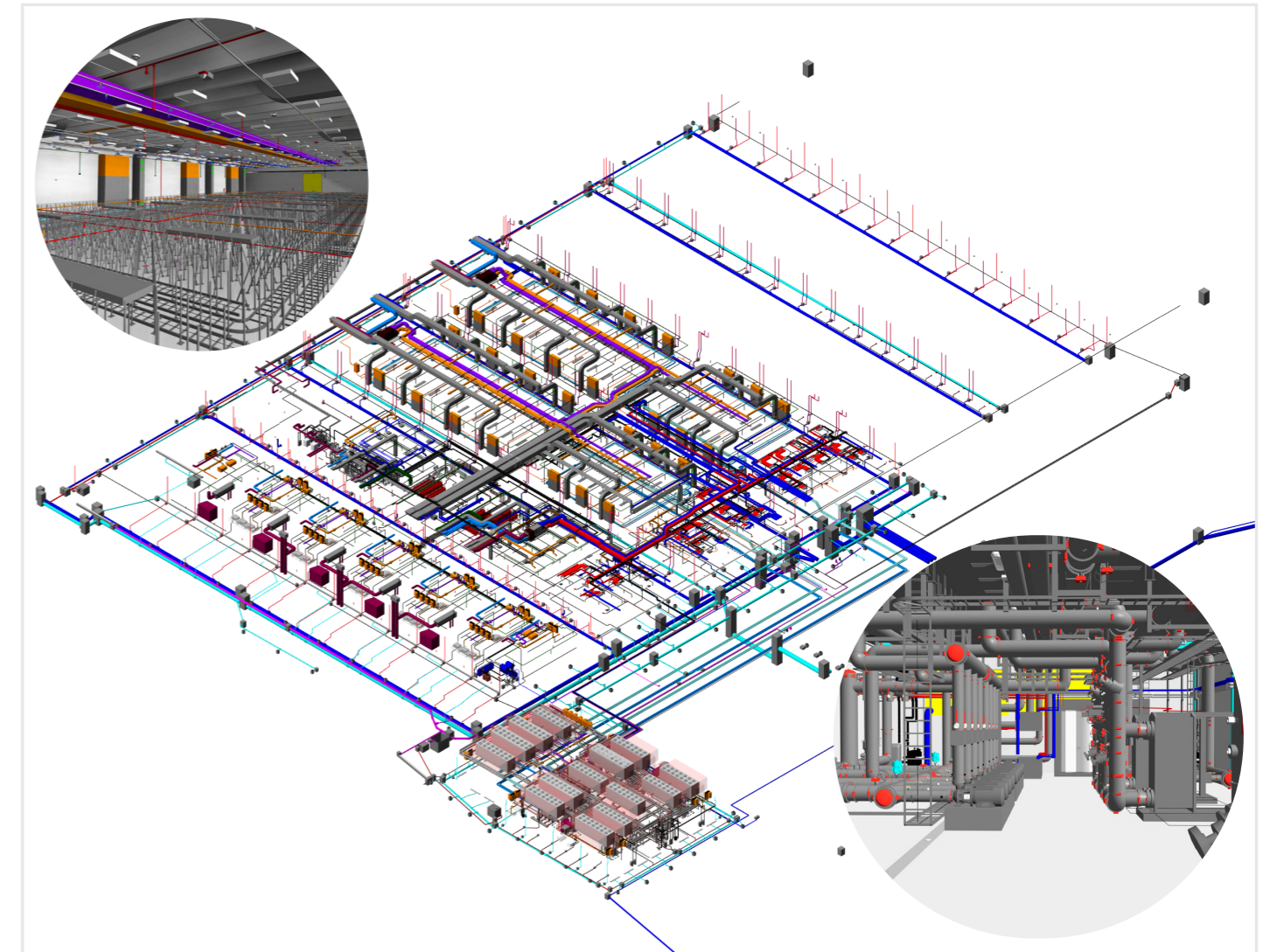



This university hospital embodies several key concepts, combining sustainability, integration with the context, innovation, well-being and functionality in a single project.



Click to see the video

▲ HEALTHCARE

Nyt OUH University Hospital

Perfect harmony between technology, context and comfort

The project for the **New Odense University Hospital** is a **complex organism, both from a technological and urban perspective**; providing a space where the relationships between patients, local community and environment weld.

The structure is composed of four blocks, hosting clinics, day hospital, offices and educational labs, crossed horizontally by two connection trajectories which shape a number of spaces, at times introverted and

immersed in the green landscapes and at times extroverted towards the city.

The **integrated design** of Nyt OUH has been developed thoroughly in **BIM technology**, performing a computerisation of the project, through which space, aesthetics and technology work together towards defining **one of the biggest hospitals in Europe**.

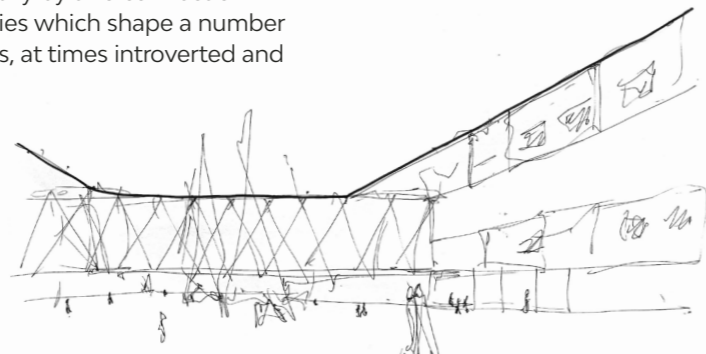

Location:
Odense, Denmark

Typology:
New construction

Year:
2018 - ongoing

Status:
Design completed, construction in progress (80%)

Dimensions:
250.000 sqm

Budget:
€ 700 mln

Client:
JV (CMB+ITINERA)

Activities:
Preliminary, detailed and executive design (architecture, structures, MEP including electrical systems and cooling systems for the two redundant data centers), Project Management support

Awards:
The Plan Award 2019 - Category: Future Hospital
BIM & Digital Award 2018 - Category: Public Buildings

Credits:
Project concept: C.F. Moller
Render: MTSYS
Photo: Andrea Zanchi



Bird's-eye render

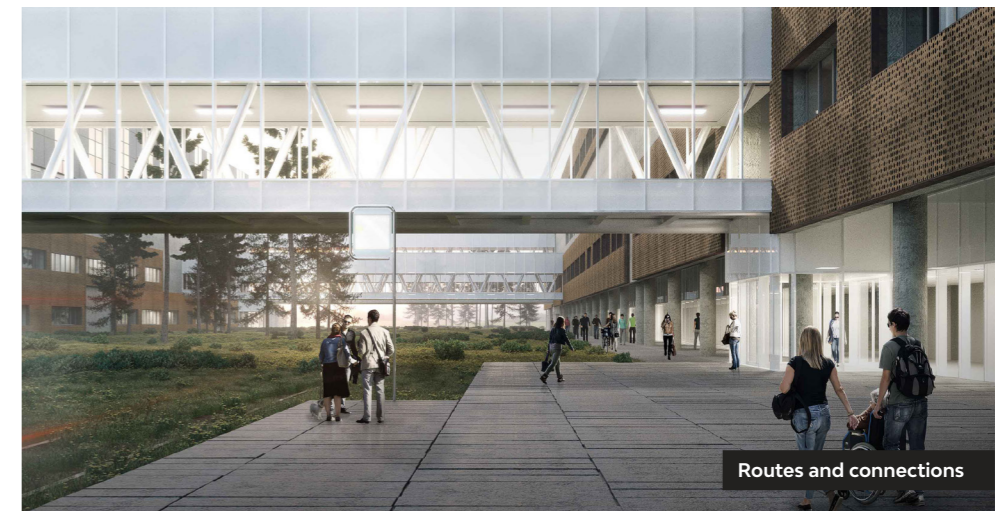

Routes and connections

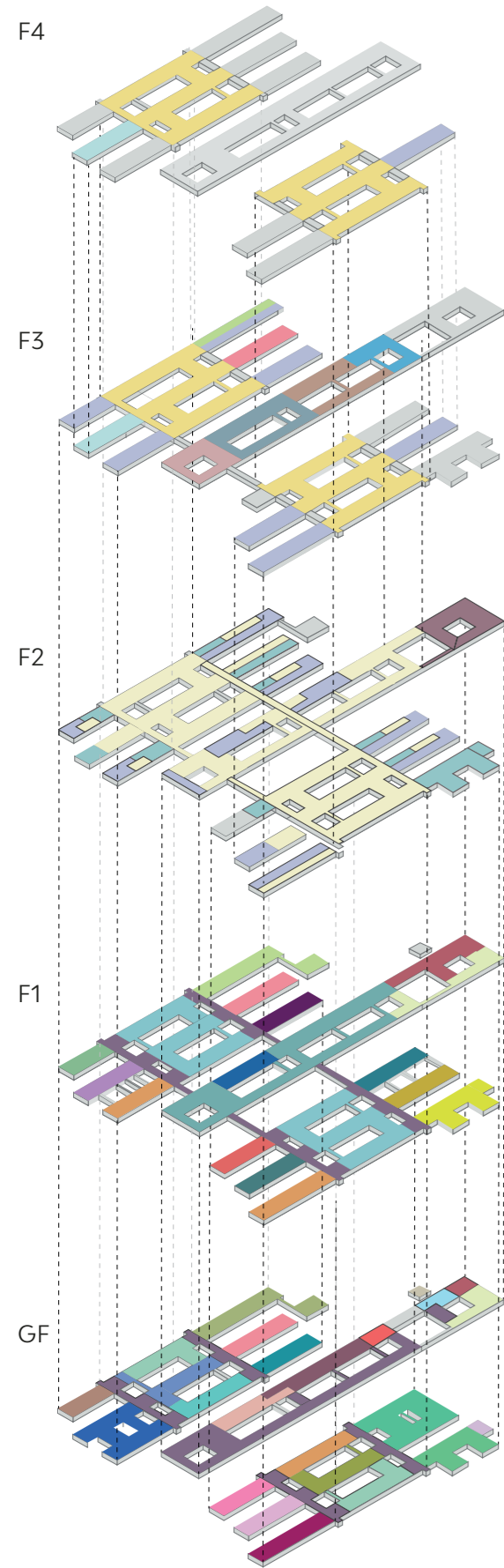

Functional layout

F4 - FLOOR 4

- Mixed inpatient wardintensive care
- Emergency inpatient ward
- Office and administration sect.

F3 - FLOOR 3

- Child psychiatry sect.
- Office and administration sect.
- Pediatric inpatient ward and inten. care
- Mixed inpatient wardintensive care
- Emergency inpatient ward
- Clinical genetics lab. dept.
- Clinical pathology lab. dept.
- Clinical biochemistry and pharmacology lab. dept.
- Clinical microbiology lab. dept.

F2 - FLOOR 2

- Simulation center
- Technical area
- Office and administration sect.
- Staff facilities

F1 - FLOOR 1

- All departments
- Clinical immunology lab. dept.
- Training center sect. (SUND)
- Intensive care sect.
- Radiology operating dept.
- Child psychiatry sect.
- Pediatric inpatient ward and inten. care
- Maternity and pregnancy inpatient ward
- Operating dept.
- Lung medicine sect.
- Emergency inpatient ward
- Mixed investigation and treatment sect.
- Hematology and rheumatology dept.
- Oncology dept.
- Pharmacy sect.
- High isolation technical area
- Otorhinolaryngology sect.

GF - GROUND FLOOR

- All departments
- Child psychiatric inpatient ward
- Pediatric inpatient ward and inten. care
- Cardiology operating dept.
- Radiology dept.
- Neonatal medicine sect.
- Day hospital sect.
- Cardiovascular medicine sect.
- Emergency room
- Clinical pathology lab. dept room
- Clinical immunology lab. dept.
- Fertility center
- Training center sect. (SUND)
- Allergology and dermatology dept.
- Nephrology and dialysis dept.
- Chapel
- Radiotherapy dept.
- Pharmacy sect.
- Endoscopy dept.
- Nuclear medicine dept.
- Mixed investigation and treatment sect.
- Ophthalmology and dentistry sect.
- Gastroenterology mixed sect.
- High isolation inpatient ward

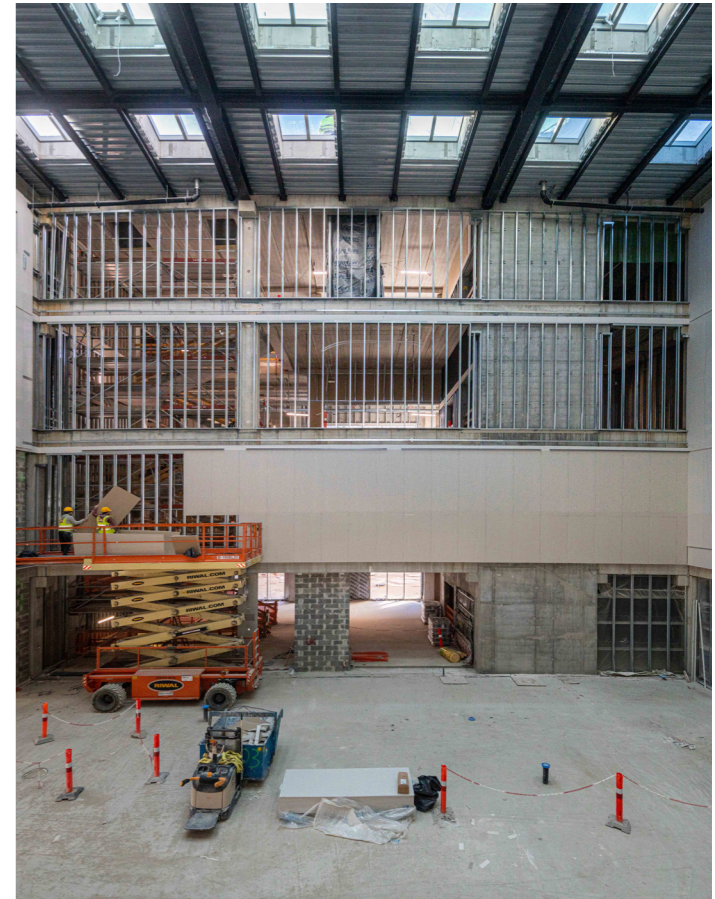
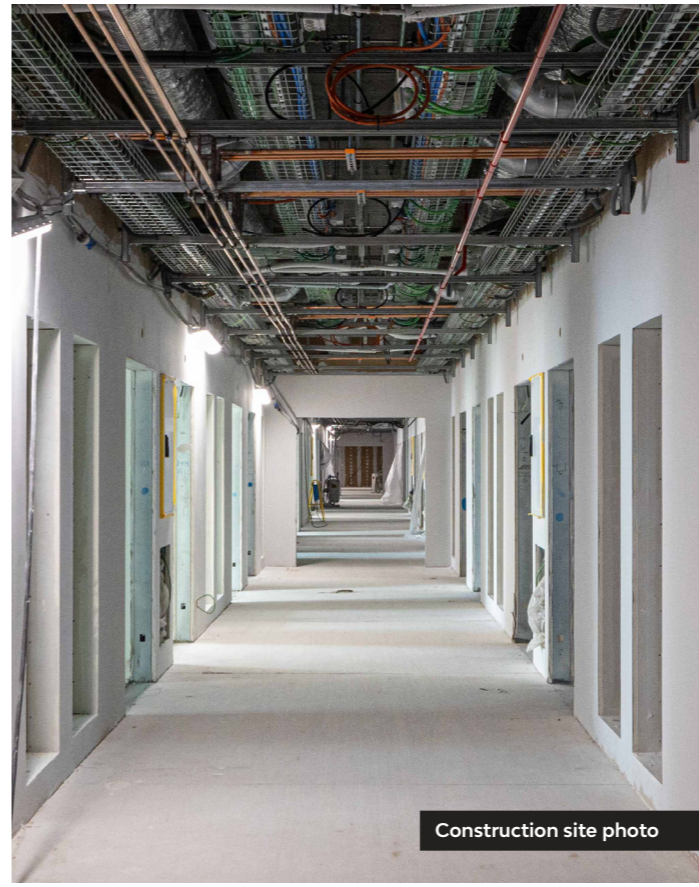

BUILDING DATA

- N+1 diesel rotary drUPS on medium voltage as backup supply
- 26 medium/low voltage substations
- 35 MW installed transformers
- 2 Data server rooms
- 2 medium voltage ring supplies
- Redundancy busbar between Power Centers
- Double power supply PDUs
- Double power supply cooling machines

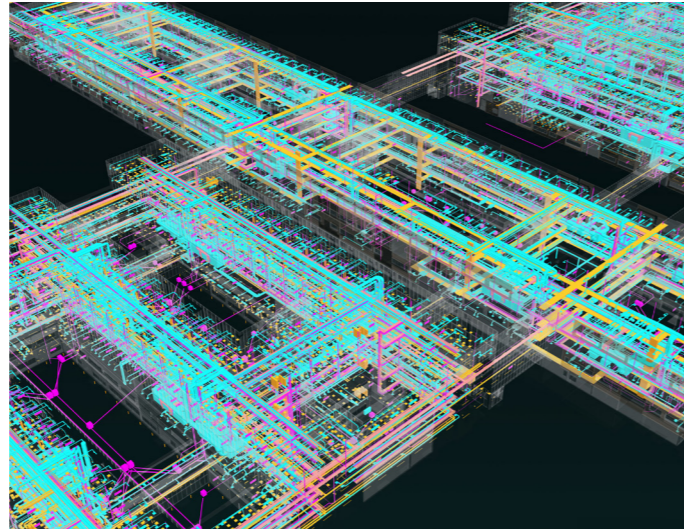

BIM model overview

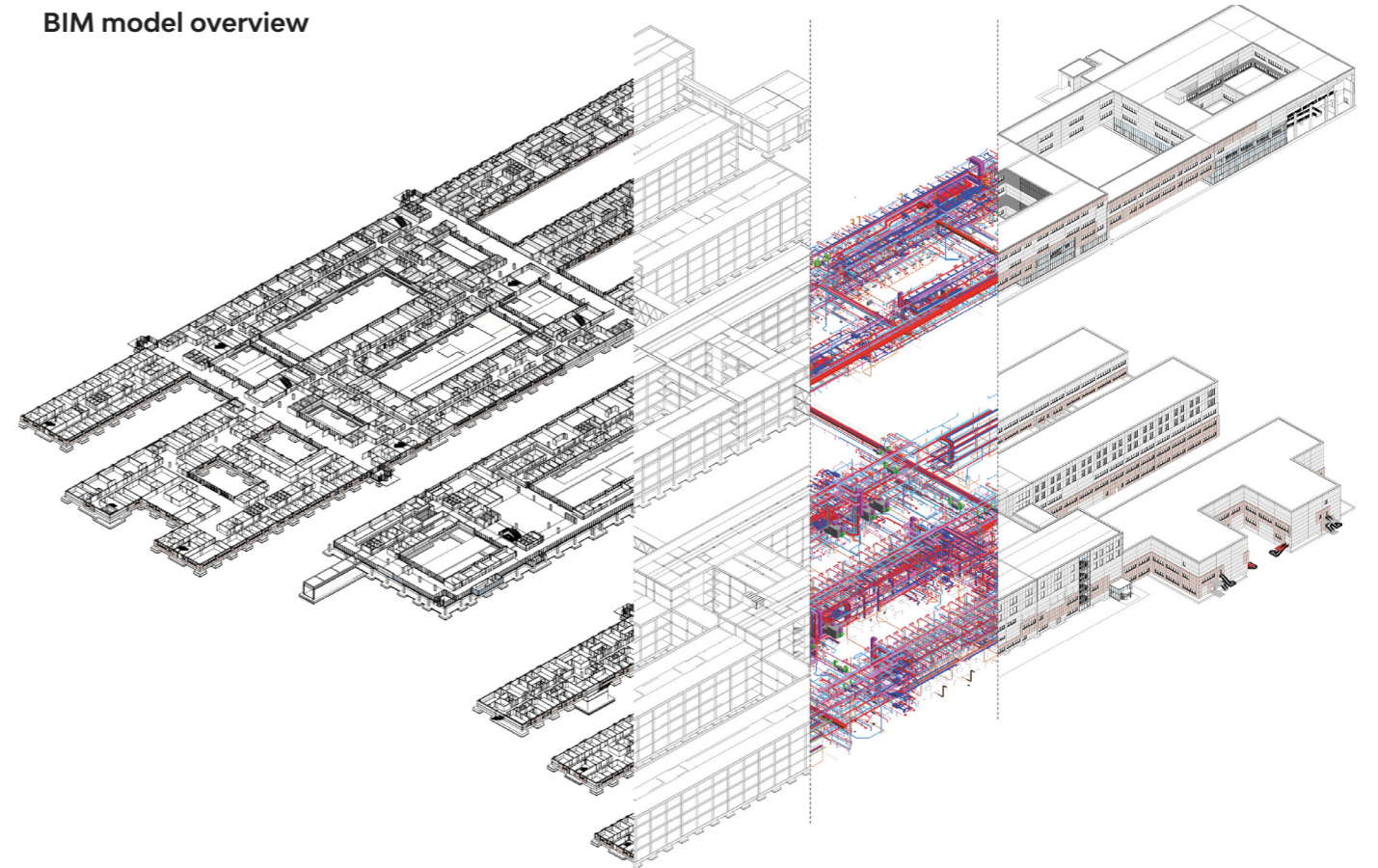

Data centers cooling functional scheme

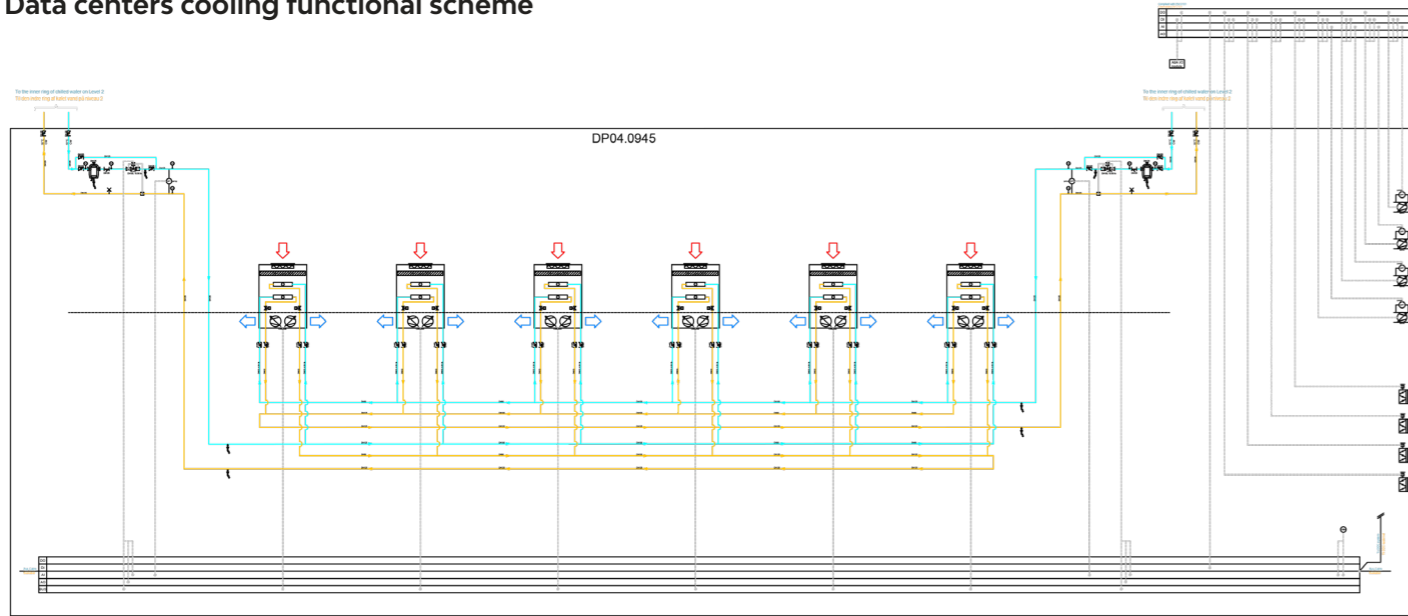

Data server layout

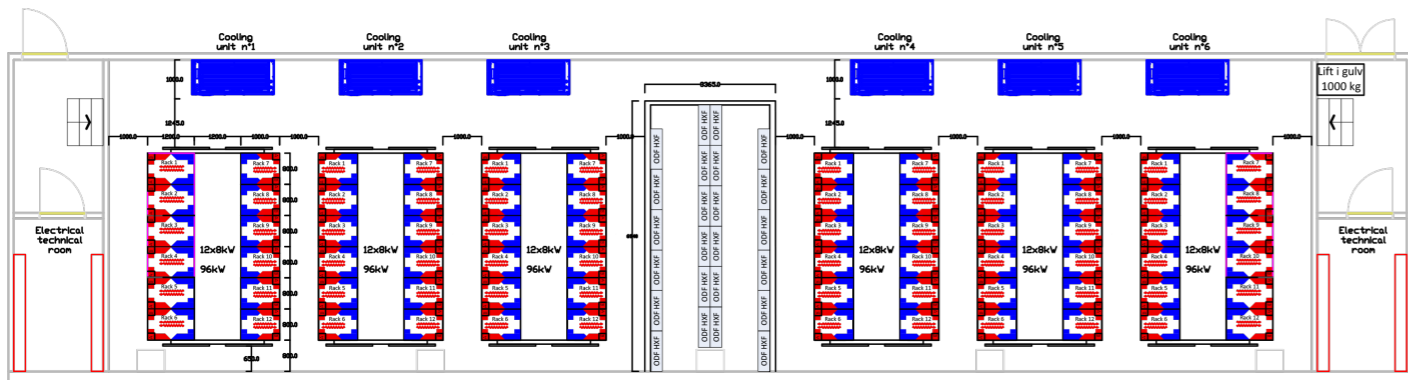

BIM model detail

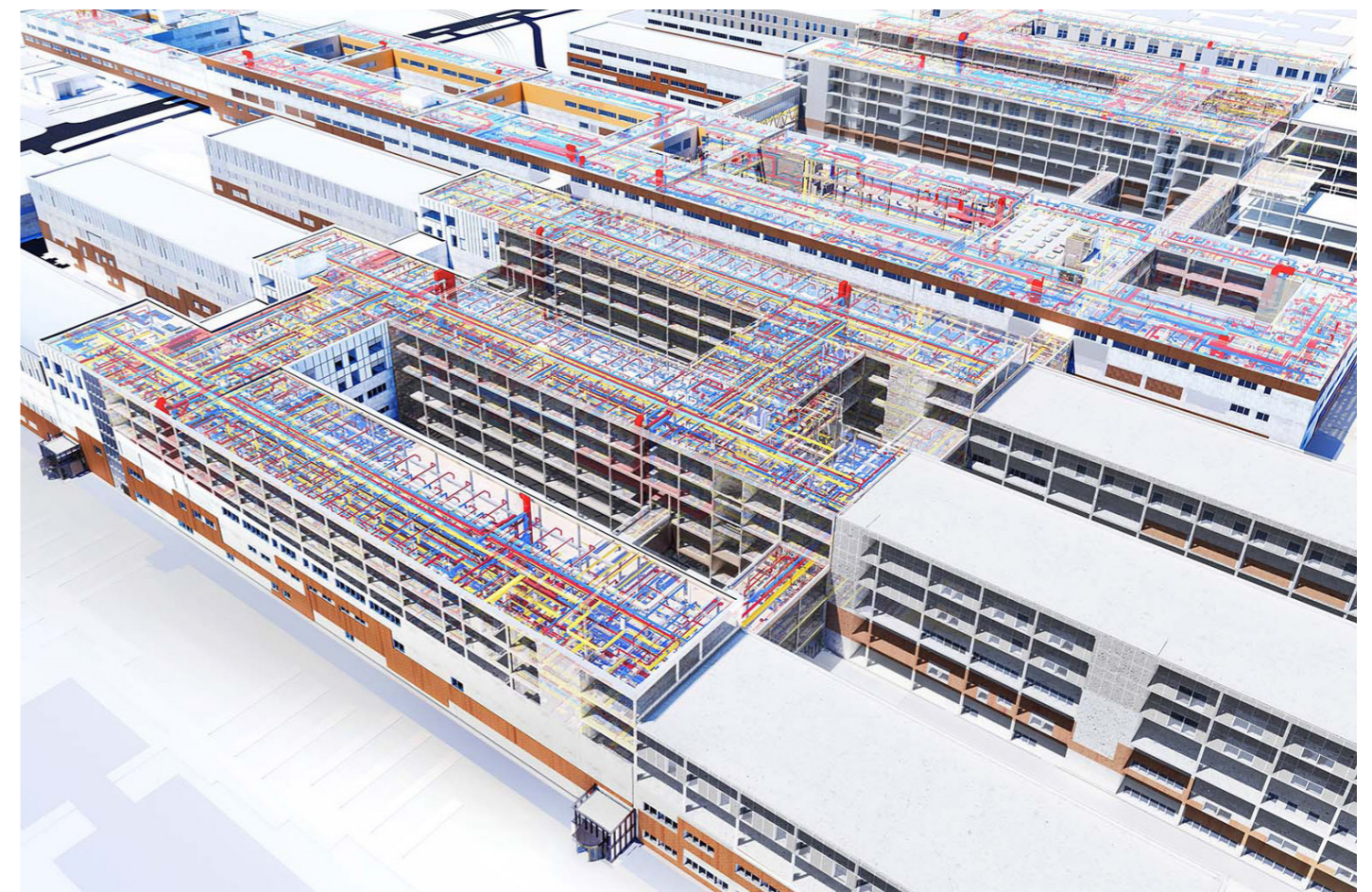



Main entrance



Garden view

A perfect combination of quality and sustainability. The added value lies in the concerted and shared effort of the various professionals involved.

HEALTHCARE

Bispebjerg Hospital

A reference point for the territory and healthcare. The new Copenhagen hospital

The project for the **new Bispebjerg hospital** represents a key intervention within the vision proposed by the Capital Region of Denmark for the development of health care services in the area.

The architectural complex develops in an area of **approximately 77.500 sqm**, within which **six pavilions** host a dense and widely articulated functional program.

There are three key departments: **emergency, operation and radiology**. These are adjoined by departments with the most contact with patients, such as pediatrics and woman & child. Operating rooms, laboratories, connection tunnels and services complete the **programmatic layout**,

making the new facility a **state-of-the-art hub** for the entire region.

In the new hospital, the design disciplines intersect forming a technological unicum with a decisive language, that is at the same time perfectly integrated from a landscape and environmental point of view.

It is an intervention of great logistical and institutional importance; and was made possible thanks to the transversal nature of the **BIM methodology**, which allows to articulate each phase of the life cycle of the new building in compliance with the purposes of the project vision and with a careful control of construction times and costs.

Location:
Copenhagen, Denmark

Typology:
New construction

Year:
2020 - ongoing

Status:
Design completed, construction in progress

Dimensions:
Approx. 89.000 sqm

Budget:
€ 230 mln

Client:
Rizzani De Eccher

Activities:
Revision of preliminary design, detailed and executive design (architecture, structures, MEP, infrastructure, landscape)

Credits:
Preliminary design: Khr Arkitekter A/S, Arup, Urbanlab Nordic, Eyp

Consultants:
Sweco - Creo Arkitekter



Construction site



Click to see the video

BUILDING DATA

- 12 MW of installed electrical power
- 3 transformer rooms
- Diesel generators to support 100% redundancy for 3 days
- 2 Data centers
- Nearly zero energy efficiency building

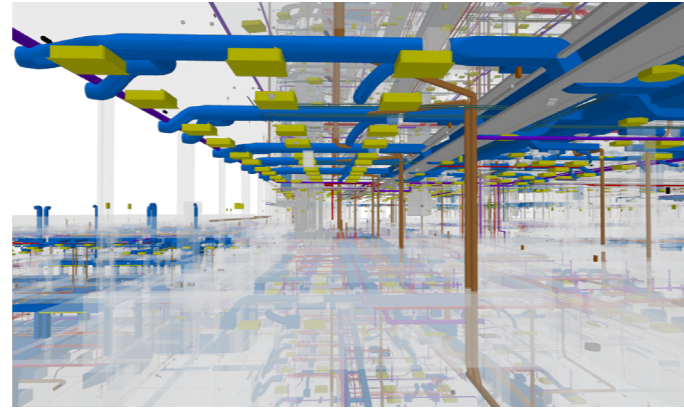

Server room details

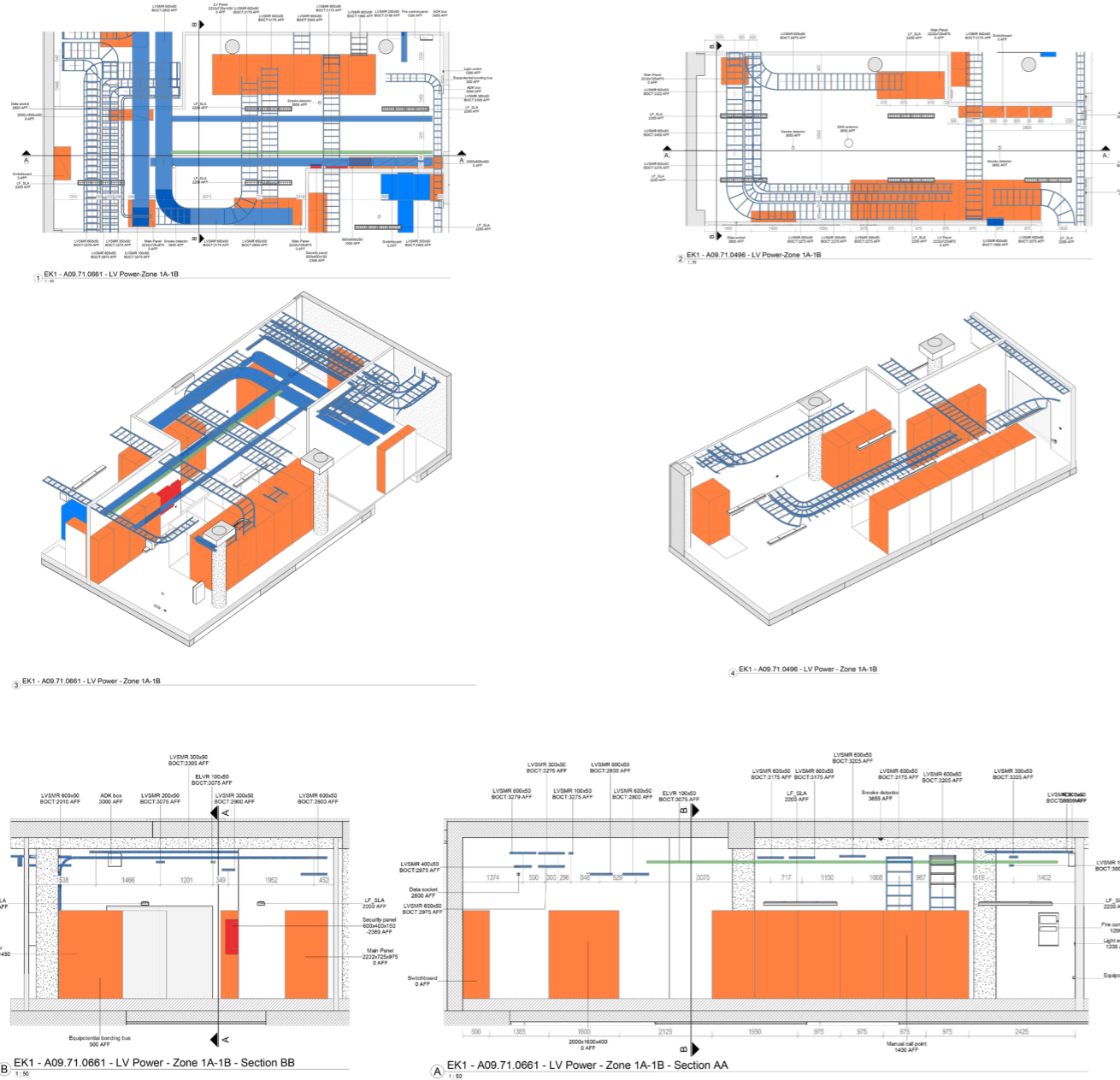

Electrical systems overview

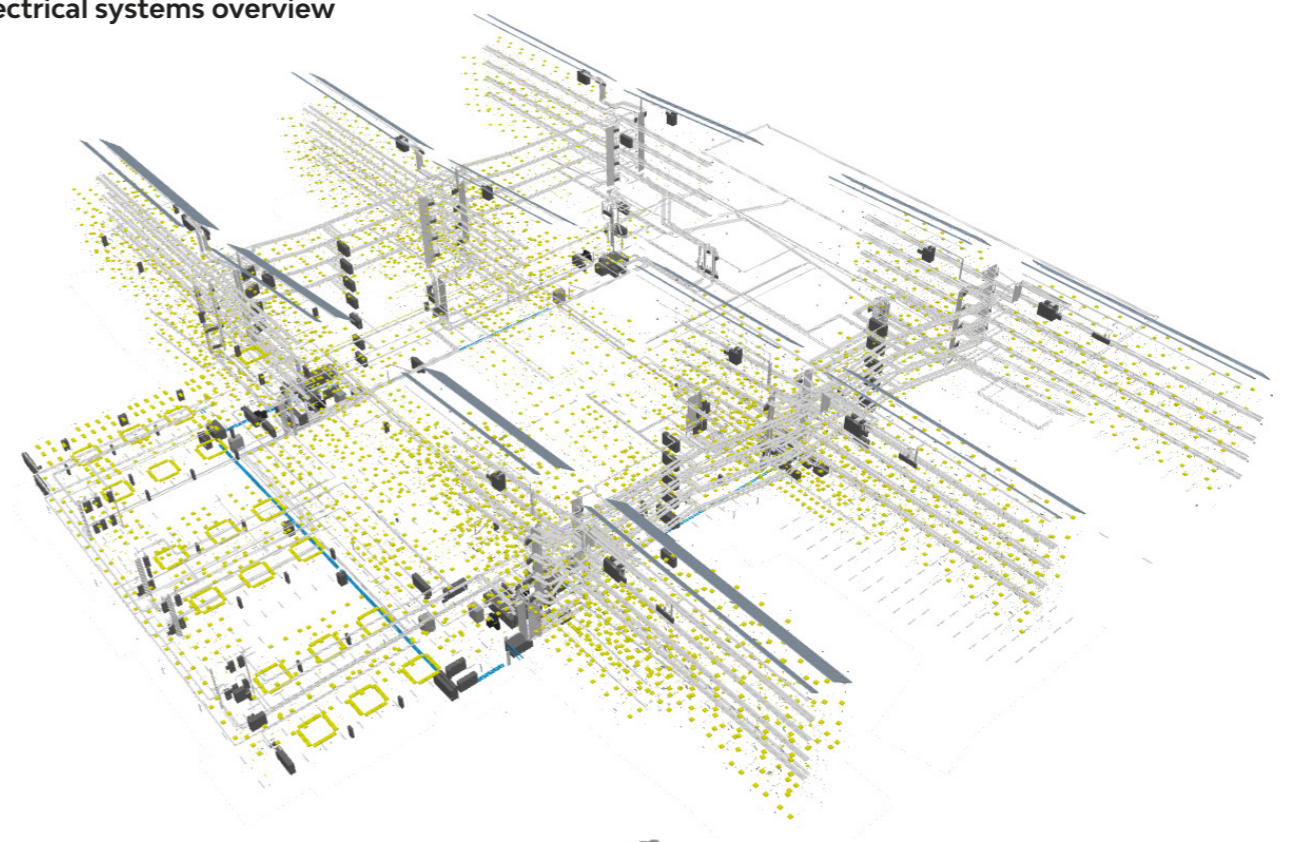

MEP model overview

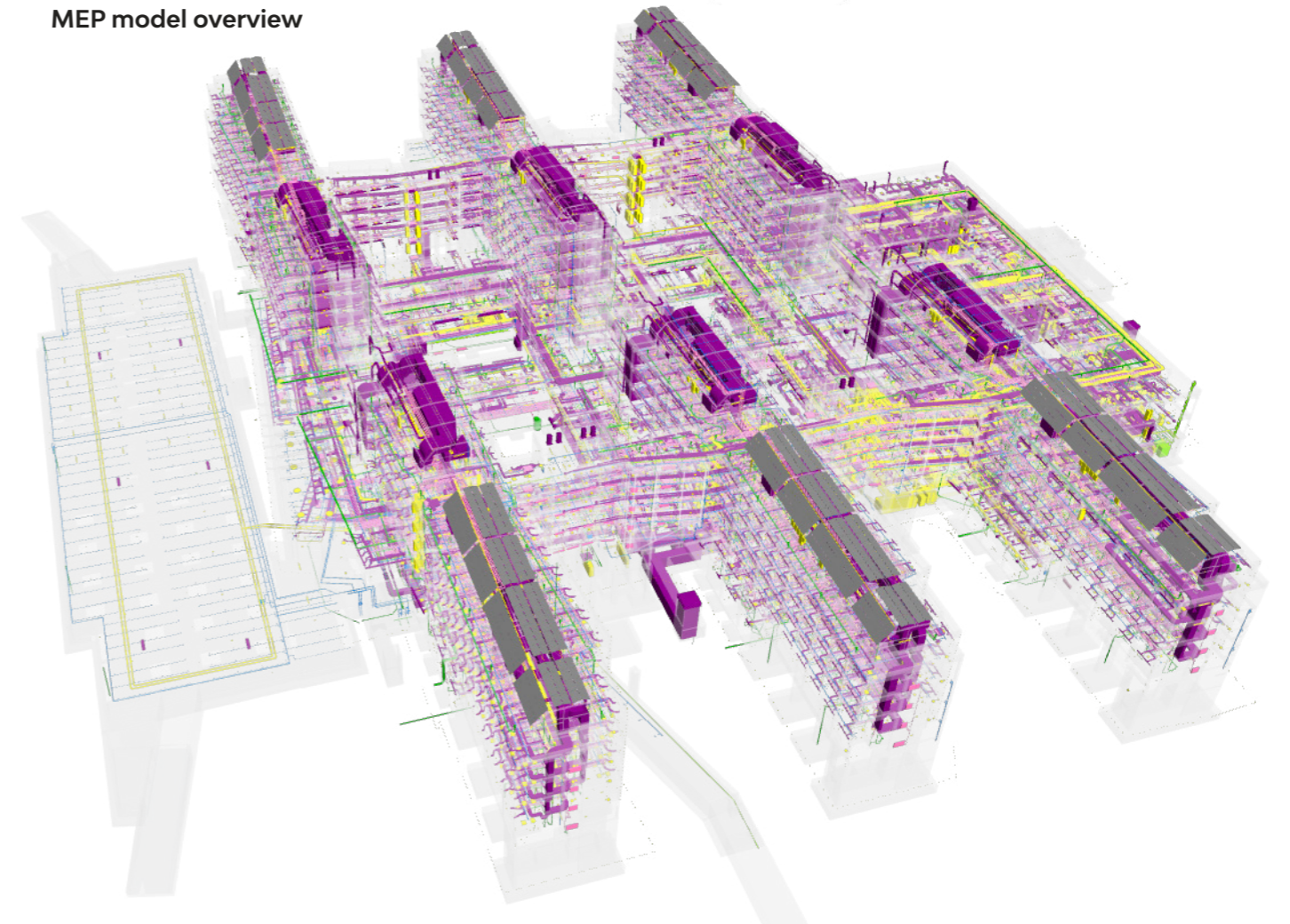



Main entrance



Side view

An avant-garde and highly functional complex, in which the technological envelope expresses sensitivity towards the surrounding area, becoming a distinctive landscape element.

▲ HEALTHCARE

Tallinn Hospital

Architecture dedicated to care. A hospital connected to the surrounding landscape

The project of the **new Tallinn Hospital** is developed on the limestone hill of Maarjamäe, in the natural setting of the Estonian capital's bay.

Modern, technological, and sustainable, the complex harmonises with the most contemporary requirements of hospital facilities and is divided into **two volumes**, which house the outpatient and treatment functions and move along the longitudinal axis of the volumetric matrix, coinciding with the main covered corridor.

At the top of the building are the **wards**, which emphasise the perimeter of the

volume and maximise the contribution of natural light.

Hospital areas are interconnected by transverse passages, following free directions, alternating with **elevated gardens, informal meeting spaces** and **views** of the **park**, the **sea**, and the **city**, participating in the psychophysical well-being of staff and users.

The **envelope** dialogues with its surroundings and moves in overlapping registers through slight folds that intercept the light, reflecting it in a play of reverberations, capable of dematerialising the mass of the base volume.

Outside, the **green campus** reflects the architectural textures of the building, becoming part of the landscape.

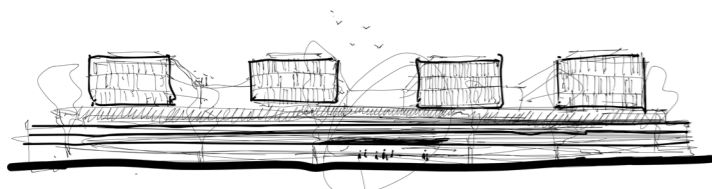

Location:
Tallinn, Estonia

Typology:
New construction

Year:
2021 - ongoing

Status:
Design completed (PD)

Dimensions:
Approx. 216.000 sqm

Budget:
€ 520 mln
€ 450 mln Works
€ 70 mln Medical equipment

Client:
Tallinn Social Welfare and Health Care Department

Activities:
Preliminary design (architecture, structures, MEP, landscape, infrastructure)

Collaborators:
3TI Progetti

Consultants:
Esplan



Entrance



Atrium

BUILDING DATA

- 30 MW of installed electrical power
- 4 transformer rooms
- diesel generators to support 100% redundancy for 3 days
- 140 air handling units
- nearly zero energy efficiency building



Transformer substation 110/20 kV - layout

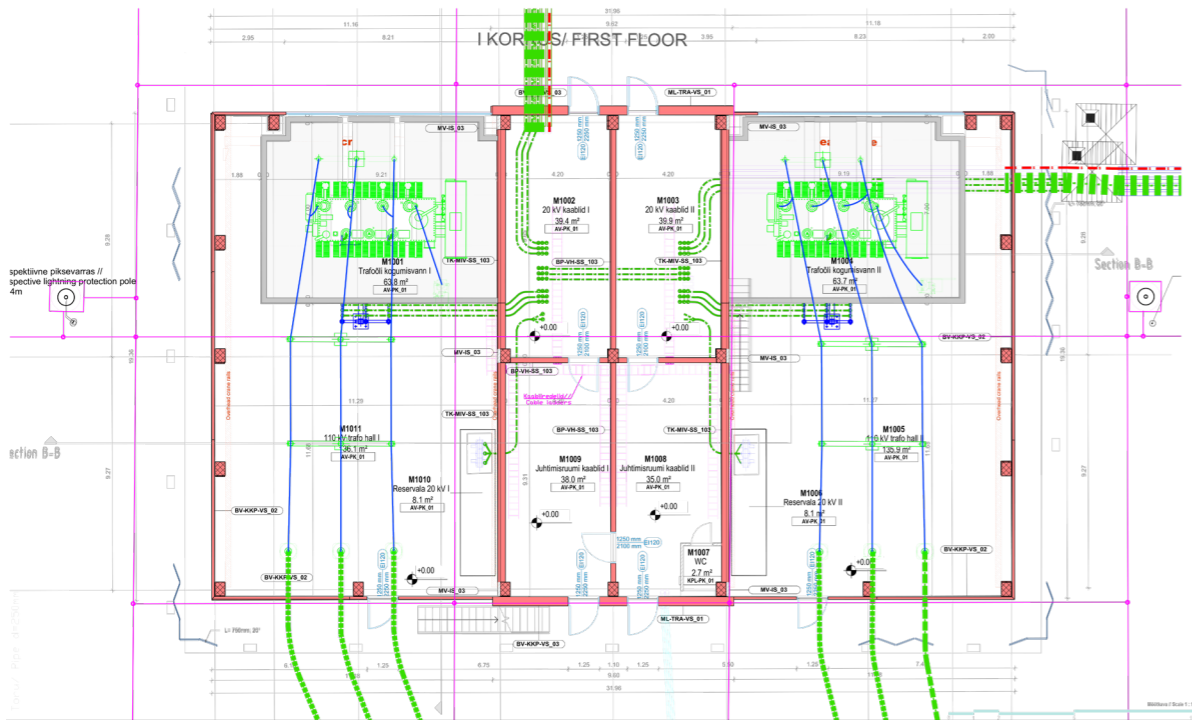

Transformer substation 110/20 kV - electrical scheme

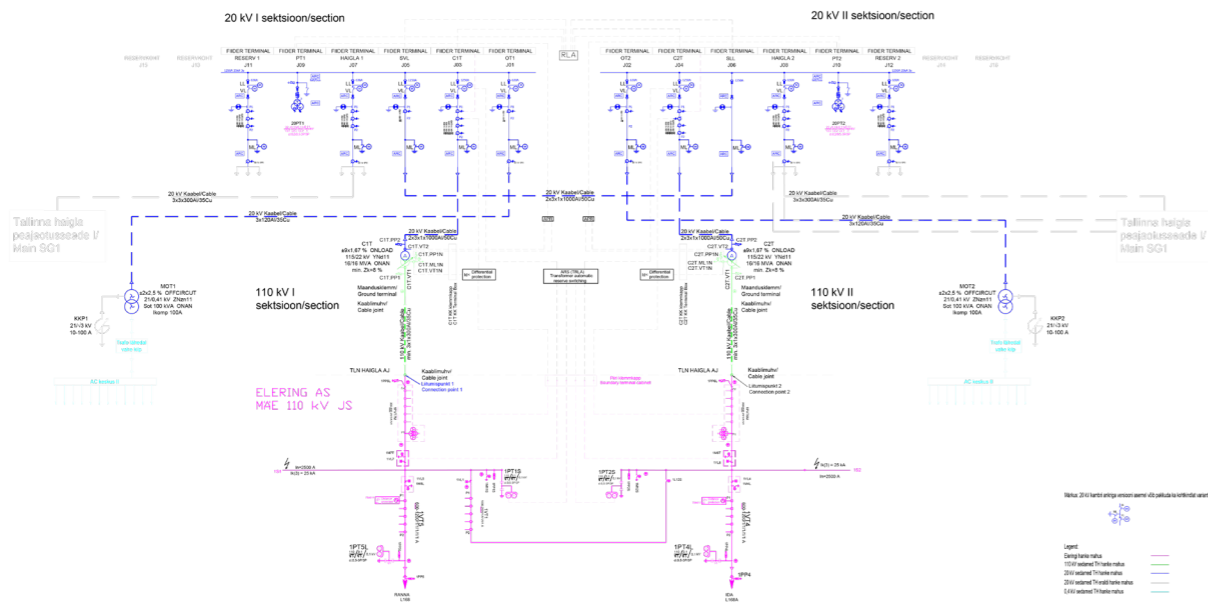

Electrical systems overview

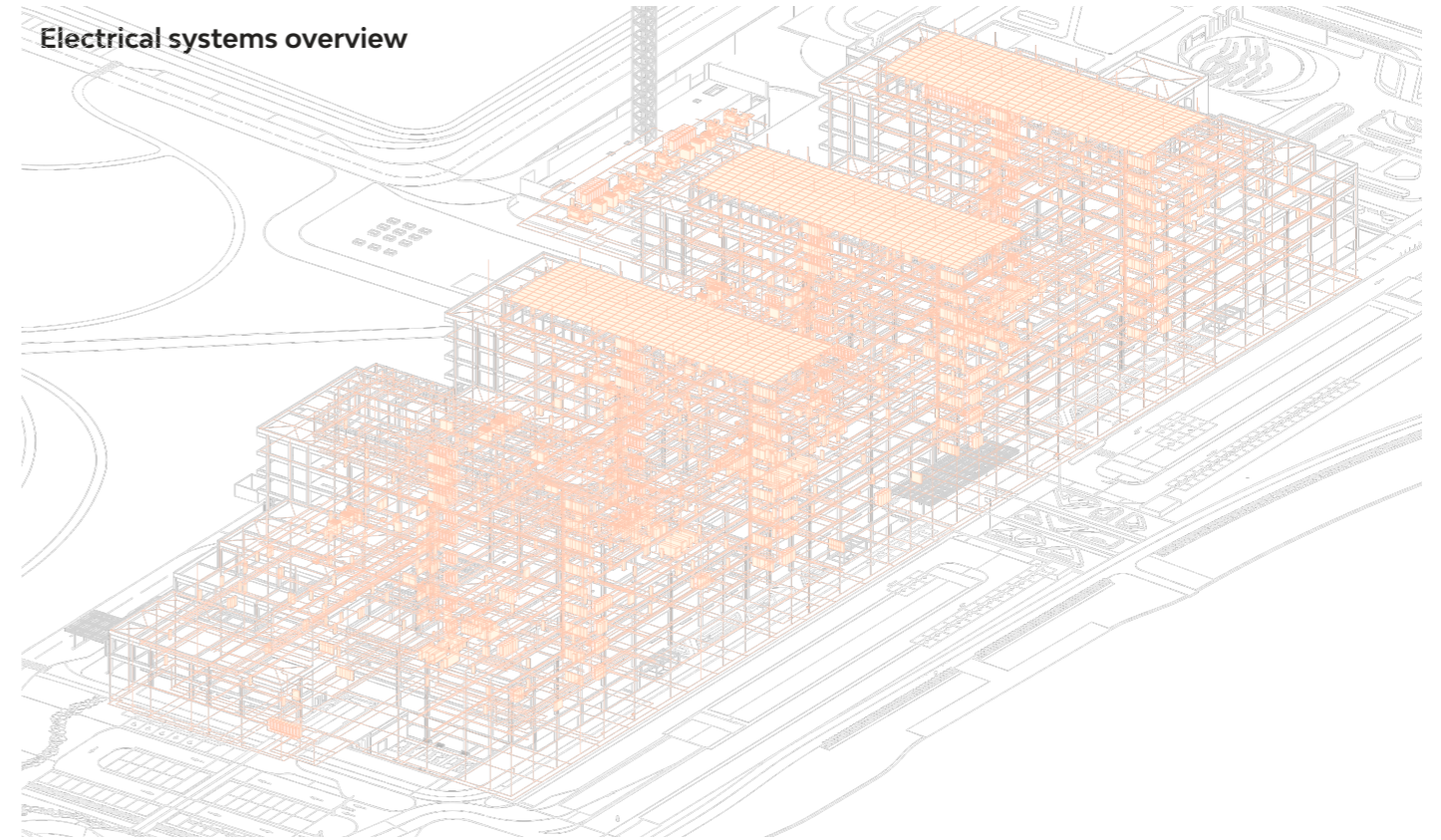

MEP model overview

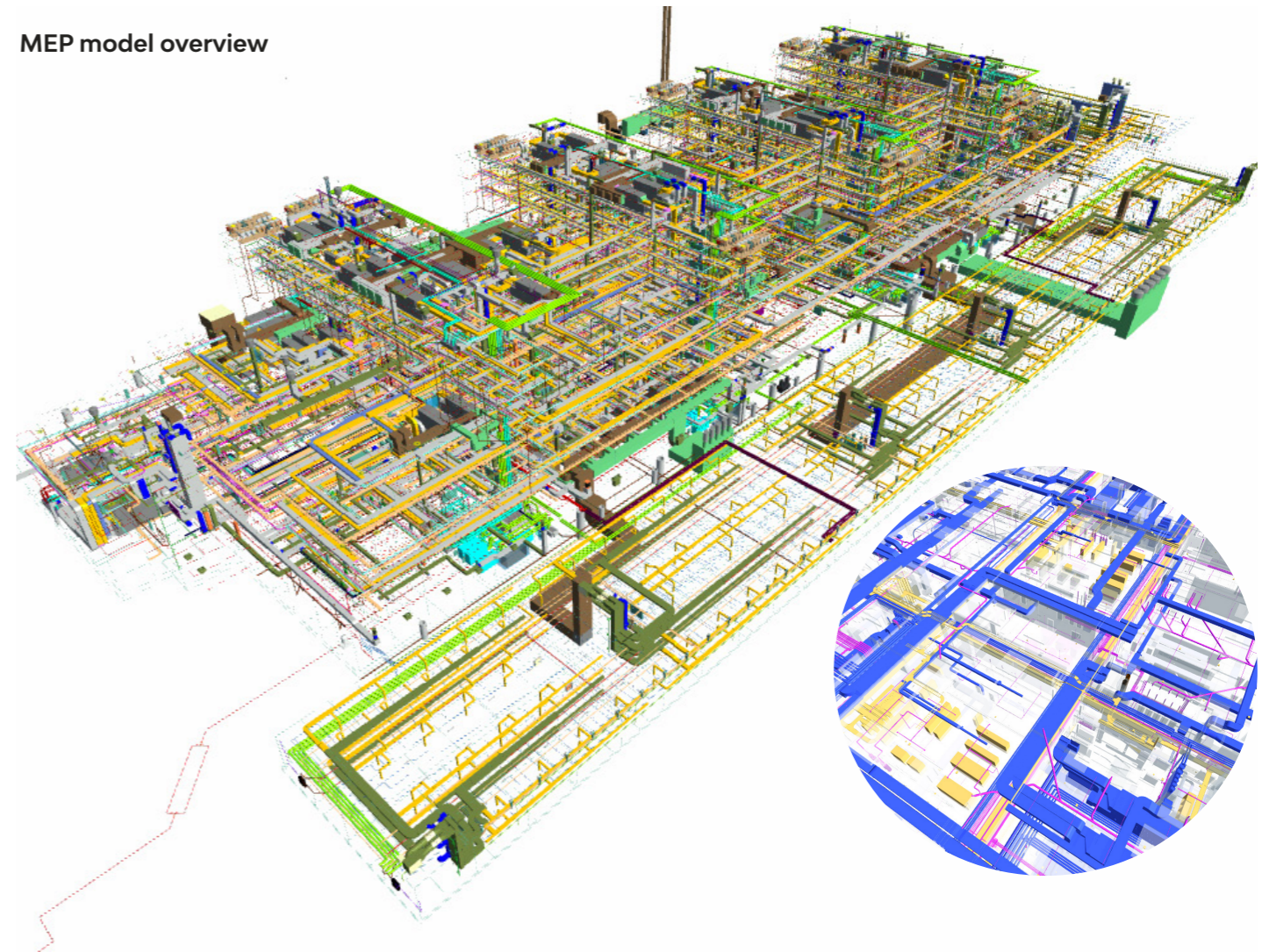

Certifications

 <p>BIM UNI PDR 74:2019 CERTIFIED COMPANY</p>	 <p>ISO 9001:2015 CERTIFIED COMPANY</p>	 <p>ISO 14001:2015 CERTIFIED COMPANY</p>	 <p>ISO 45001:2018 CERTIFIED COMPANY</p>	 <p>UNI PDR 125:2022 CERTIFIED COMPANY</p>	 <p>SA 8000:2014 CERTIFIED COMPANY</p>
---	--	---	---	--	---

 <p>ASSOCIATE OF CONFINDUSTRIA ASSOIMMOBILIARE</p>	 <p>MEMBER OF OICE</p>	 <p>MEMBER OF EFCA</p>	 <p>MEMBER OF CNETO CENTRO NAZIONALE EDILIZIA E TECNICA OSPEDALIERA</p>	 <p>MEMBER OF GREEN BUILDING COUNCIL ITALIA</p>	 <p>LEGAMBIENTE IDENTITY CARD</p>
--	---	---	--	---	--

 <p>BIM QUALITY ENVIRONMENT POLICY</p>	 <p>SOCIAL RESPONSABILITY POLICY</p>	 <p>GENDER EQUALITY POLICY</p>
--	---	---



ATI | Project

CREATING A BETTER REALITY

PISA

MILAN

BELGRADE

ODENSE

COPENHAGEN

PARIS

GENEVA

TALLINN